

# Tension Load Cell

## > Model TS21

Crane Weighing, Tower Testing,  
Tension Load cell,  
Option : Connector cable type.

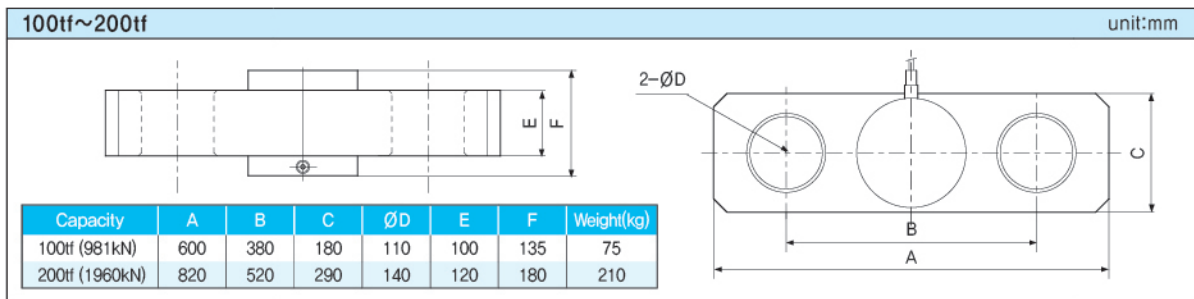
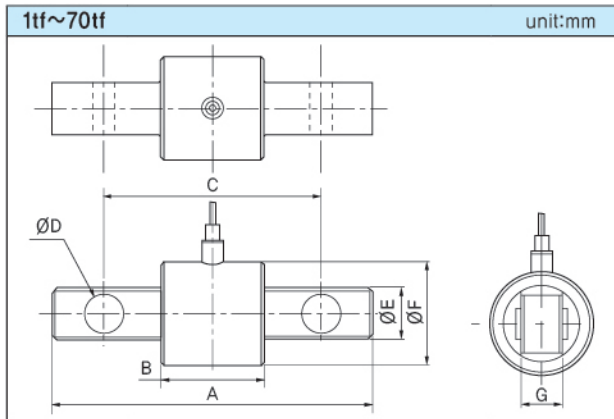

## >SPECIFICATIONS

Specifications	Accuracy
Rated capacity(R.C)	1tf, 2tf, 3tf, 5tf, 10tf, 20tf, 30tf, 50tf, 70tf, 100tf, 200tf
Rated output(R.O)	1mV/V 0.5%
Nonlinearity	0.5% of R.O.
Hysteresis	0.1% of R.O.
Repeatability	0.1% of R.O.
Zero balance	±1% of R.O.
Temperature effect on rated output	0.1% of LOAD/10°C
Temperature effect on zero balance	0.05% of R.O./10°C
Temperature range, compensated	-10°C to 60°C
Temperature range, safe	-20°C to 80°C
Terminal resistance, input	350Ω ±10Ω
Terminal resistance, output	350Ω ±5Ω
Insulation resistance bridge/case	2000MΩ
Excitation recommended	10V
Safe overload	150% R.C.
Cable length	Ø7mm 4core, 10m

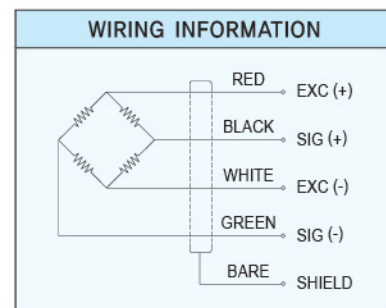

## >DIMENSIONS TABLE

unit:mm

Capacity	A	B	C	ØD	ØE	ØF	G	Weight(kg)
1tf (9.81kN)	140	70	110	18	32	50	20	
2tf (19.6kN)	163	70	120	22	39	50	25	2
3tf (29.4kN)	180	63	128	27	49	60	30	
5tf (49.0kN)	234	80	168	37	59	70	40	3.5
10tf (98.1kN)	310	100	210	37	89	100	40	9
20tf (196kN)	400	120	285	62	120	135	70	23
30tf (294kN)	428	128	288	64	120	135	75	26
50tf (490kN)	508	148	342	75	145	160	98	43
70tf (686kN)	620	150	410	100	170	210	100	68

★Specifications are subject to change without notice.